

版次	ECN 编号	修改内容	日期	修改人

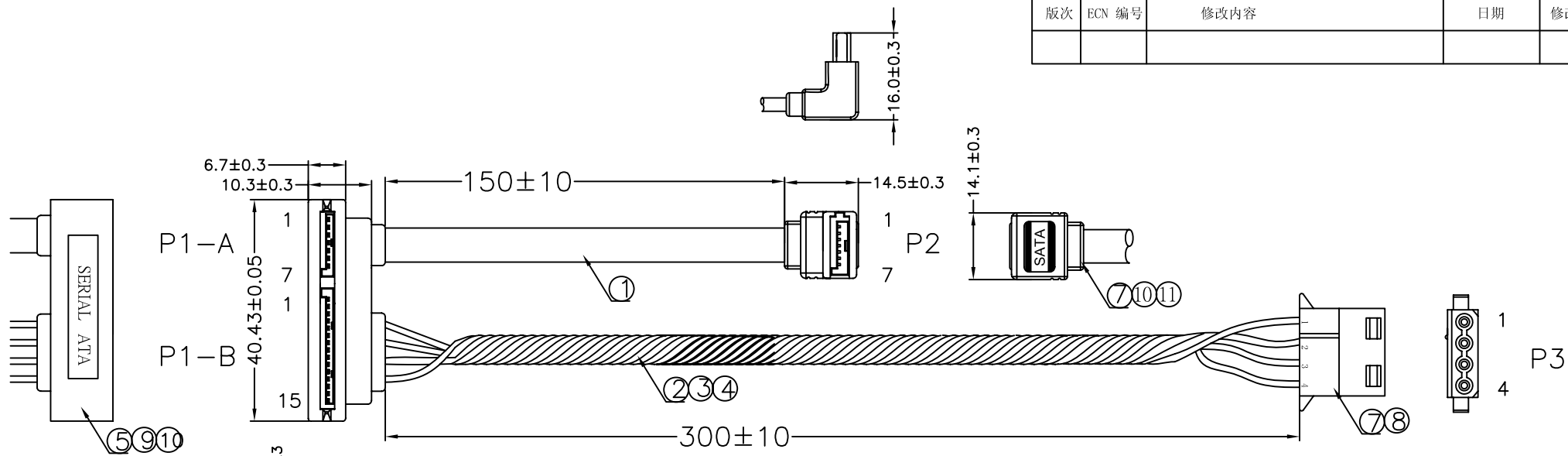

PIN ASSIGNMENT

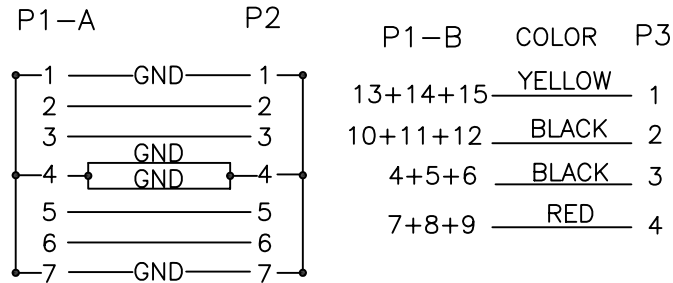

ELECTRICAL TEST:

1).100% OPEN&SHORT WITH MISS WIRE TEST

2).TEST CODITION:

a).CONDUCTIVE RESISTANCE:2 ohm Max.

b).INSULATION RESISTANCE:10M ohm Min.

c).HI-POT:300V DC

10	OVER MOLD:PVC 35P BLACK(RoHS)	10.5g
9	INNER MOLD:LOW DENSITY PE PLASTIC(RoHS)	4.2g
8	TER:PH5.08mm BRASS TIN PLATED, 母端子(RoHS)	4PCS
7	HSG:PH 5.08mm 1*4P/M HSG WHITE NYLON66(RoHS)	1PCS
6	SATA 7P/F PLASTIC:PBT BLACK,CONTACT:镀金3u",CRIMP TYPE (RoHS)	1PCS
5	SATA 7+15P/F PLASTIC:LCP BLACK,CONTACT:镀金3u",CRIMP TYPE,无尖角 (RoHS)	1PCS
4	UL1007 22AWG TS PVC COLOR:YELLOW OD:1.6mm L=345mm (RoHS)	1PCS
3	UL1007 22AWG TS PVC COLOR:RED OD:1.6mm L=345mm (RoHS)	1PCS
2	UL1007 22AWG TS PVC COLOR:BLACK OD:1.6mm L=345mm (RoHS)	2PCS
1	UL2725 (26AWG*2C+AL/MY+28AWG*2D)*2F JACKET COLOR: BLACK OD=2.2*7.8mm L=180mm(RoHS)	1PCS

ITEM	DESCRIPTION	Q'TY
------	-------------	------

未标示公差尺寸值 公制单位 .±0.15 .0±0.10 .00±0.05 .000±0.03 ANG.=±2° ANG.0=±0.5°	原始设计者 / 日期:	EBE TECHNOLOGY (HK) LIMITED			
	单位 (UNITS)	mm	视角	品名 (NAME):	
	材料 (Mtl)		SATA 7+15P/F TO SATA 7P/F + 4P HSG		
	核准 (APP'D)		料号 (PART NUMBER)		
品质标记	校对 (CHECK)	图号 (DRAW)		客户料号 (Customer Part No.)	
特殊特性= <input checked="" type="checkbox"/> 重点检验= ▼	绘图 (DRAW)	hubery	比例 (SCALE)	FULL	图纸 (SIZE)
		A4	页次 (PAGE)	1/1	版次 (REV.)
					X0